

Surface burner Concave

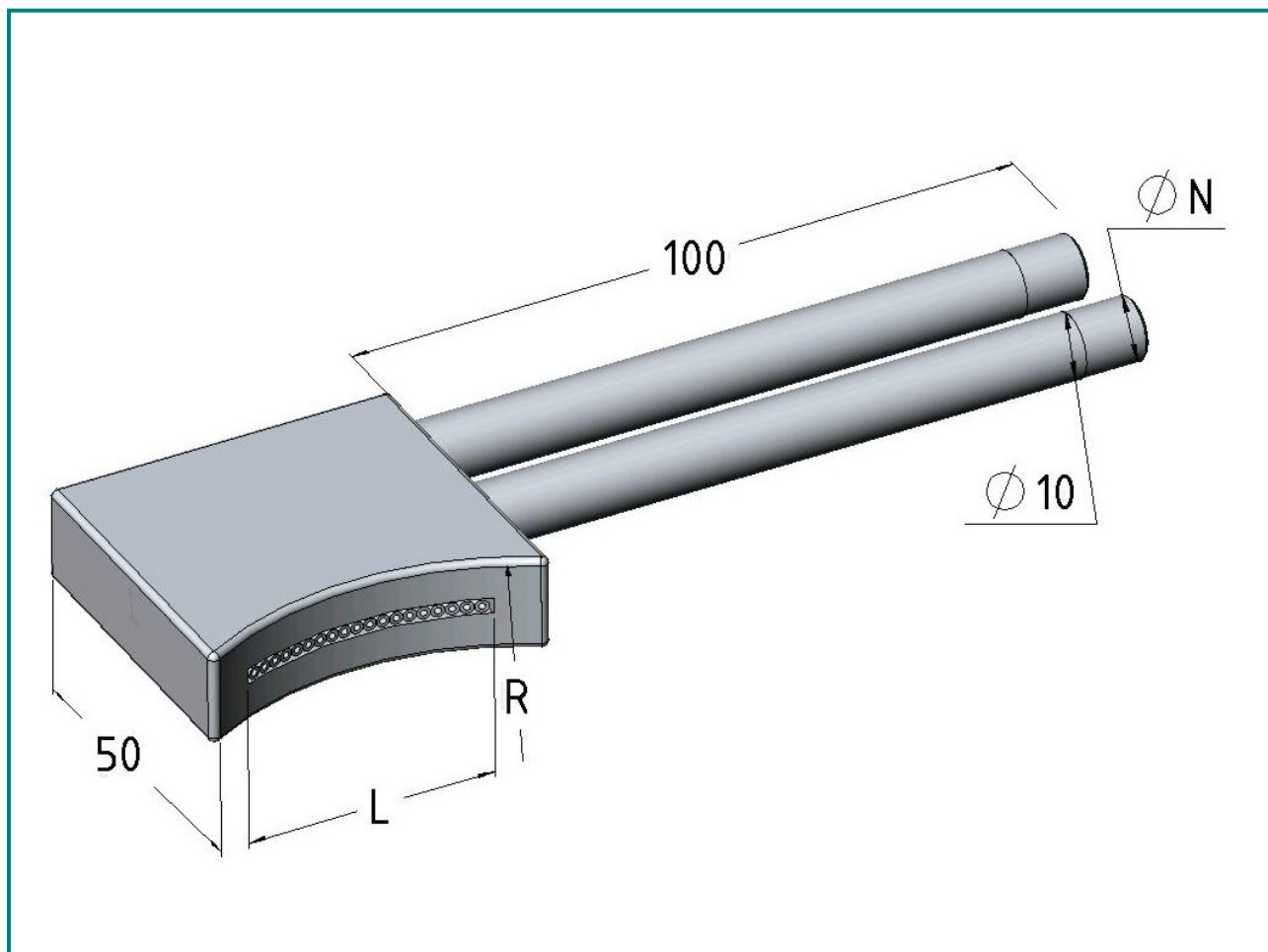

The Hornung surface burner is a special gas burner for the heat treatment of glass and other materials. The burner gives a very constant and even flame

Order No.	L mm	R mm	Thread N
13015035	15	35	1/8 NPT
13025035	25	35	1/8 NPT
13028050	28	50	1/8 NPT
13038050	38	50	1/8 NPT
13038070	38	70	1/8 NPT
13063100	63	100	1/8 NPT
13075100	75	100	1/8 NPT
13100100	100	100	1/8 NPT

Andere Abmessungen und Ausführungen auf Anfrage !

Technical data:

Material: Stainless steel
Gas: gas/oxygen

Hornung Quality standard

The company Hornung is certified to **DIN EN ISO 9001**
All single parts are manufactured, assembled and tested in house.
The finished parts are therefore under the criteria of our exact quality control with 100% final control